

PULSAR Inox
PI / WI
Points de supportages





PULSAR INOX

Nouveauté 2020 – Points de fixations inchangés



Série	Taille	Longueur	Côtes des suspension [mm] avec embout butée (KSP):		Nombre de points de suspensions
			A	B	
P.IX	1	1195	129	937	4
	2	1795	129	1537	4
	3	2395	369	1657	4
	4	2995	519	1957	4

Type P - lisse

Installation avec embout butée

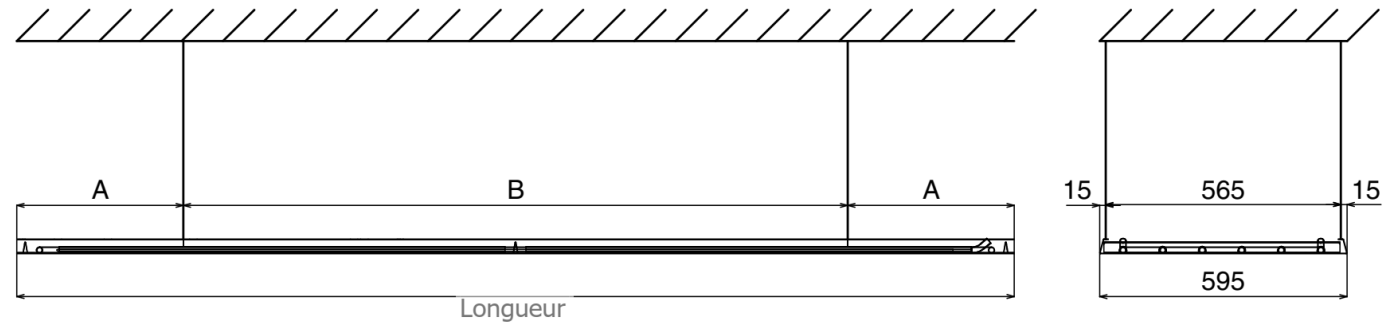
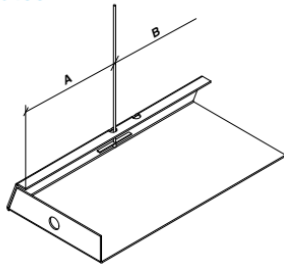



PULSAR INOX

Nouveauté 2020 – Points de fixations inchangés



Type W - lisse

Série	Taille	Longueur	Côtes des suspension [mm] avec embout butée (KSP):		Nombre de points de suspensions
			A	B	
W.IX	1	1234	180	874	4
	2	1858	180	1498	4
	3	2482	432	1618	4
	4	3106	580	1946	4

Installation avec embout butée

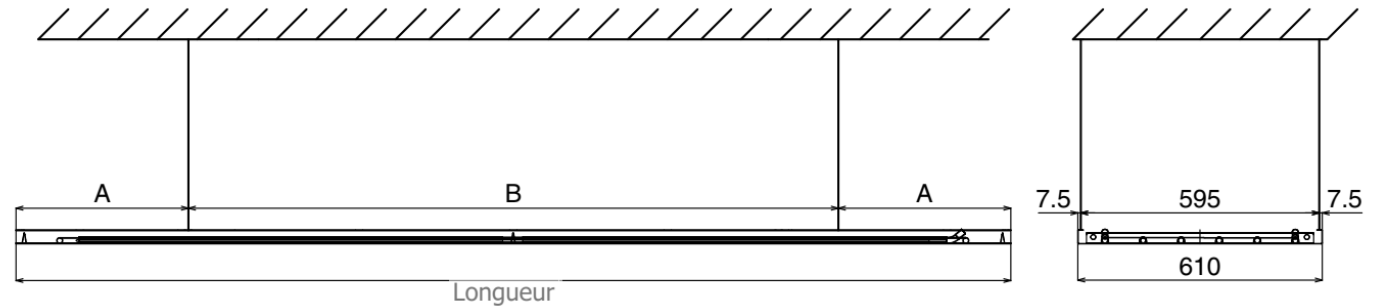
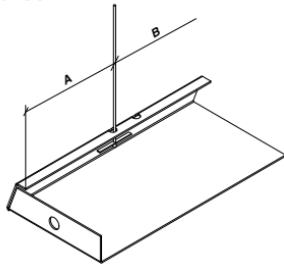



PULSAR INOX

Nouveauté 2020 – Points de fixations inchangés



Série	Taille	Longueur	Côtes des suspension [mm] avec embout butée (KSP):			Nombre de points de suspensions
			A	B	C	
PI.IX	1	1195	180	-	835	4
	2	1795	180	-	1435	4
	3	2395	180	1017,5	2035	6
	4	2995	180	1317,5	2635	6

Type P – perforé intégralement

Installation avec embout butée

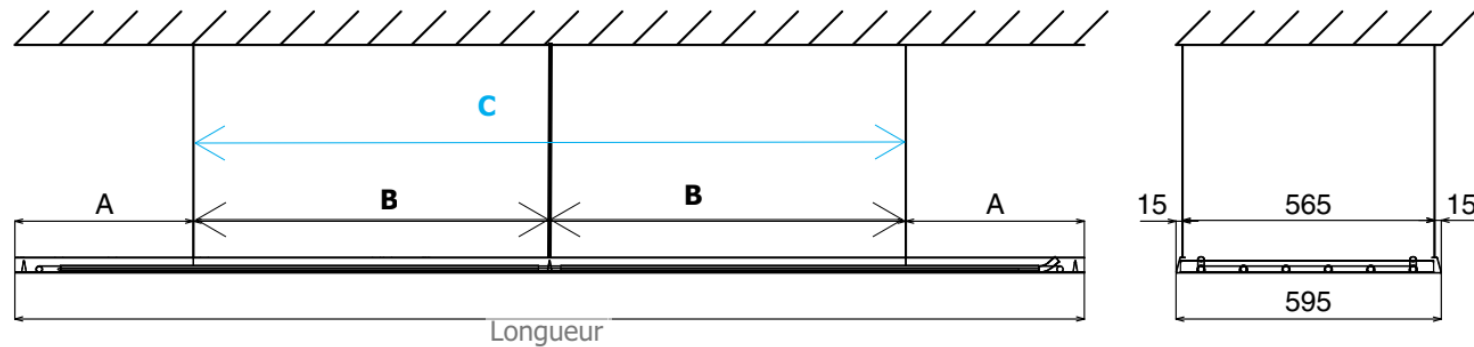
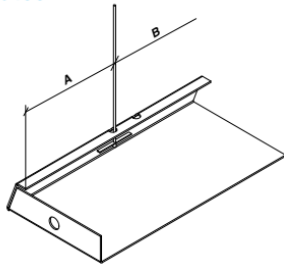



PULSAR INOX

Nouveauté 2020 – Points de fixations inchangés



Série	Taille	Longueur	Côtés des suspension [mm] avec embout butée (KSP):			Nombre de points de suspensions
			A	B	C	
WI.IX	1	1234	129	-	976	4
	2	1858	129	-	1600	4
	3	2482	129	1112	2224	6
	4	3106	129	1424	2848	6

Type W – perforé intégralement

Installation avec embout butée

